

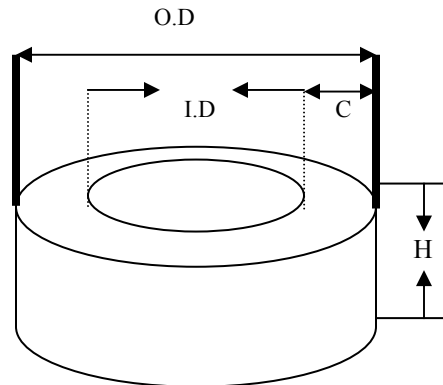

## CUSTOMER COIL SPECIFICATIONS



COIL WEIGHT LBS or KGS	HEIGHT H INCHES or MM	OUTSIDE DIAMETER OD INCHES or MM	INSIDE DIAMETER ID INCHES or MM	WIRE / CABLE DIAMETER	
				MIN	MAX

**LINE SPEED** \_\_\_\_\_ ( IF IN LINE WITH EXTRUSION – YES  )  
**TYPE OF WIRE/CABLE:** SOFT  HARD  FLEXIBLE  FLAT  ROUND   
 STEEL  ALUMINUM  COPPER  OTHER \_\_\_\_\_  
**BINDER:** YES  NO  ( SINGLE HEAD COILER ONLY )  
**APPLICATION:** IN LINE WITH EXTRUDER  REWIND LINE   
**ACCUMULATOR REQUIRED:** YES  NO   
**PAYOFF REQUIRED:** YES  NO  \*  
**HEAT SHRINK SYSTEM REQUIRED:** YES  NO   
**AUTO PALLETIZING SYSTEM REQUIRED:** YES  NO   
**\*PAYOFF FORM REQUIRED**



## MOTORIZED PAY OFF

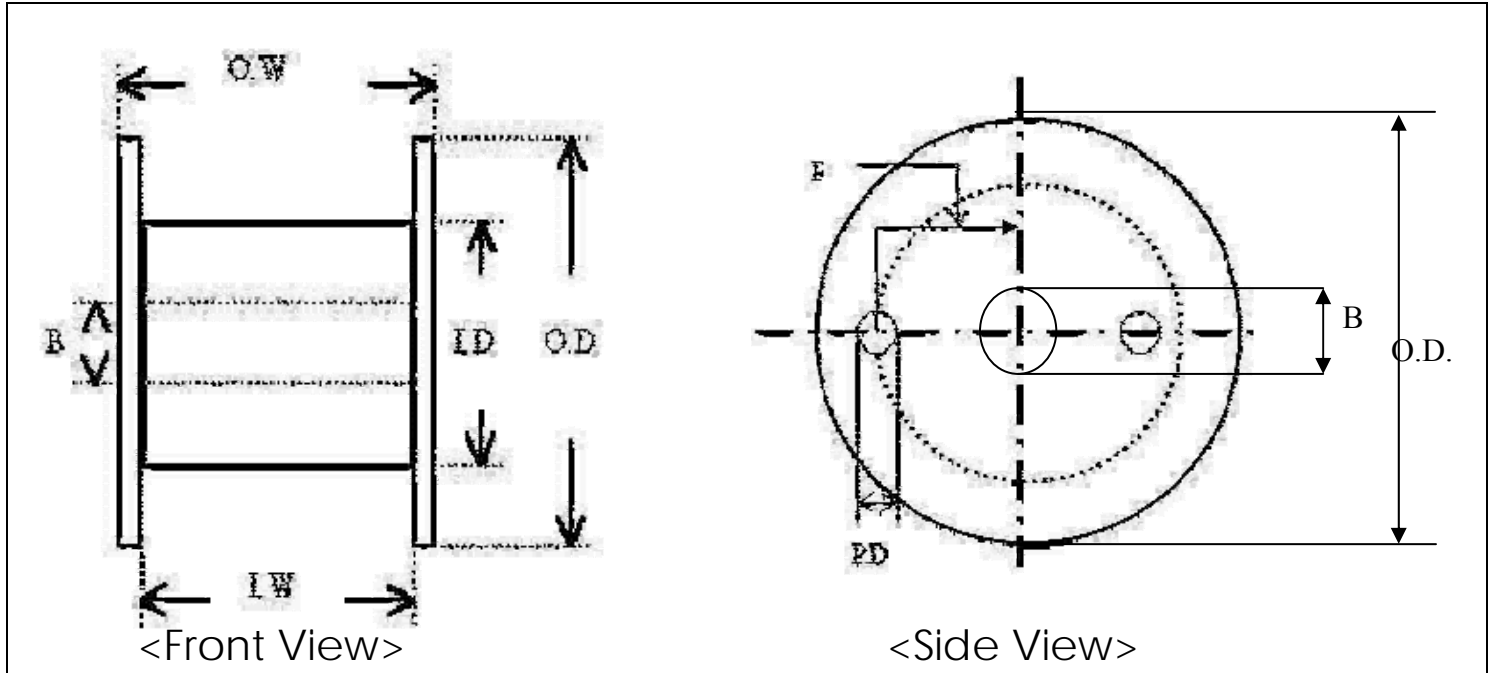

### 1. Weight of Bobbin:

\_\_\_\_\_ Lbs to \_\_\_\_\_ Lbs (empty)  
 \_\_\_\_\_ Lbs to \_\_\_\_\_ Lbs (full loaded)

### 2. Application:

In Line with Extrusion Line     Rewinding Line

### 3. Diameter of Wire/Cable

\_\_\_\_\_ to \_\_\_\_\_ (Overall Diameter)

4. Small Reel:    O.D: \_\_\_\_\_ I.D: \_\_\_\_\_ B: \_\_\_\_\_  
 I.W: \_\_\_\_\_ O.W: \_\_\_\_\_ P.D: \_\_\_\_\_ P: \_\_\_\_\_

5. Big Reel:    O.D: \_\_\_\_\_ I.D: \_\_\_\_\_ B: \_\_\_\_\_  
 I.W: \_\_\_\_\_ O.W: \_\_\_\_\_ P.D: \_\_\_\_\_ P: \_\_\_\_\_